

# COLT<sup>®</sup>



# MODERN DESIGN

## BUILT ON DECADES OF EXPERIENCE

Texas Aircraft started in 2016, but our heart was formed decades earlier. With a team who has built more than 300 planes amassing approximately 150,000 flight hours to their credit to design the Colt.

The results are the Colt 100. It is a valued priced LSA with a sleek and stylish design. Most of all it is safe and a lot of fun to fly. It is the only American made LSA featuring a trifecta of superior features.

- semi cantilever, high wing design
- all aviation grade aluminum airframe with all solid metal rivets
- a welded chromoly passenger safety cell with an optional GRS ballistic parachute.

In 2018 we designed and built an all new manufacturing facility specifically for Colt production in Hondo, Texas just west of San Antonio.

We'd love to talk to you, learn your needs and answer any question you may have.

We hope you'll love the Colt as much as we do.

# COLT®



# WHY TEXAS AIRCRAFT?

With decades of experience, we are able to offer you the best benefits in just one LSA airplane. The Colt.

- Large cabin space allowing room for you, your passenger, and your baggage.
- Low noise level within the cabin.
- Equipped with the most modern avionics panel on the market.
- Comfortable seats made from leather.
- Equipped with an optional parachute by GRS (Galaxy Recovery System).
- Powerplant provided by 100hp Rotax Engines.

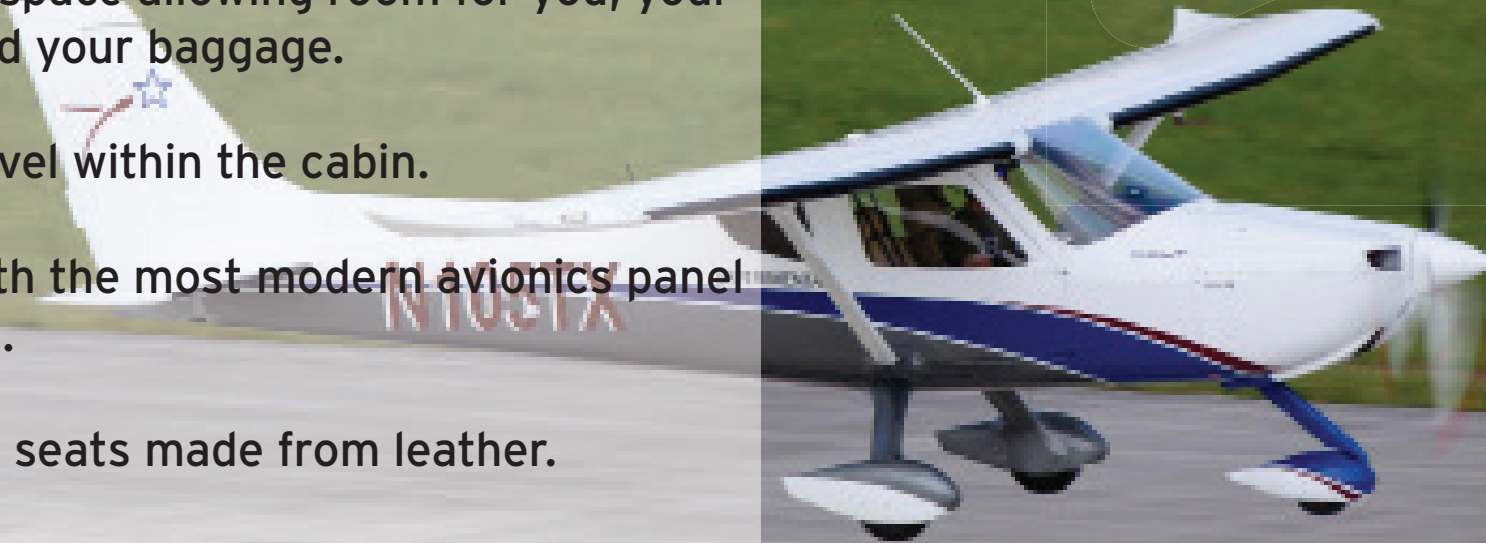



Rotax 912 ULS



Sterna S69CBMR 3 Blade



2 Seats

**Maximum Cruise Speed:** 118 knots TAS

**Cruise Speed (V<sub>e</sub>) @ 75% Power:**  
105 knots TAS

**Stall Speed - Clean (V<sub>s</sub>):** 44 knots CAS

**Stall Speed - FLAPS (V<sub>so</sub>):** 38 knots  
CAS

**Maximum range (full tanks):** 800 nm

**Range w/ two adults (200lbs each):**  
300 nm

**Fuel Economy:** 3.6 US Gal/h (@ 55%  
power, 90 knots TAS, 6500ft)

**Takeoff Distance (50ft Obstacle):**  
1,085 feet

**Landing Distance (50ft Obstacle):**  
1,044 feet

**Climb Rate (V<sub>y</sub>):** 760 fpm

**Service Ceiling:** 14,500

**Empty Weight:** 851 lbs\*\*

**Useful Load:** 469 lbs empty\*\*

*\*All specifications are subjected to change without notice.*

*\*\*Weight may vary depending on the aircraft's configuration.*



# COLT SAFETY FEATURES

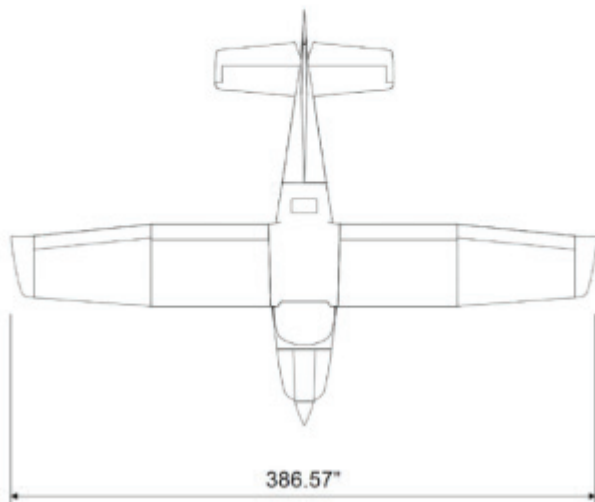
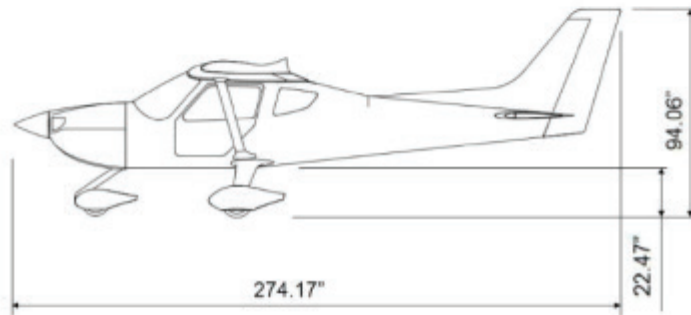
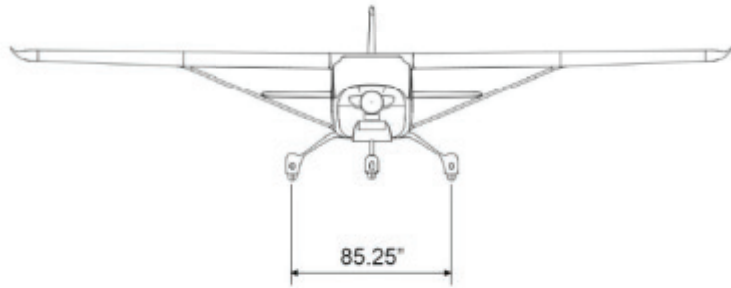

- *Welded Chromoly Steel Safety Cell*
- *All Aviation-Grade Aluminum Airframe*
- *Galaxy GRS Ballistic Parachute System (optional)*
- *Four-point Passenger Safety Harnesses*
- *Docile Flight Characteristics Slow Stall Speed*
- *Manufacturers Full Two Years Limited Warranty*

<b>LENGTH</b> .....	23"3'
<b>HEIGHT</b> .....	7"7'
<b>WINGSPAN</b> .....	32"2'
<b>CABIN HEIGHT</b> .....	3"8'
<b>SEAT WIDTH</b> .....	16"
<b>MAXIMUM BAGAGE WEIGHT</b> .....	44lbs
<b>BAGAGE AREA VOLUME</b> .....	38" X 22"

# AVIONICS AND EQUIPMENTS

COLT S US\$165,000.00

## VFR

### SINGLE SCREEN

- G3X Touch 10.6" display w/ EMS
  - GTX 45R Transponder
  - ADS-B OUT
  - GTR 200B COM Radio
  - Analogic Instruments Backup (Air speed, Bank, Compass)
- Optional Equipment
- Bose 6 Pins LEMO Headset Connector: \$1,000

COLT SL US\$189,000.00

## VFR + Auto Pilot

### SINGLE SCREEN

- G3X 10.6" display w/ EMS
  - GTX 45R Transponder
  - ADS-B IN/OUT
  - GTR 200B COM Radio
  - Analogic Instruments Backup (Air speed, Bank, Compass)
  - 3 axis Autopilot (Pitch, Roll, Yaw)
  - Instrument Panel lights
  - Bose 6 Pins LEMO Headset Connector
- Optional Equipment
- Garmin G5 Electronic Flight Instrument \$4,000
  - Second PFD/MFD Garmin G3X Touch-screen 10" \$5,800

**ROTAX**<sup>®</sup>  
**GARMIN**



*Colt S Panel*



*Colt SL Panel with Auto Pilot*



*Colt SL with G5 and Second Screen*



# EXTERIOR OPTIONS AND PRICES

## 1. Exterior Standard Design - Option 1 (up to 3 colors)

Main Base in Pure White with Polyurethane Paint

Wing Tips painted in Polyurethane Color

N-Number in Vinyl

Vinyl Scheme in Standard options

*\*Metallic or Pearl Paint and Vinyl have Additional cost*



## 2. Exterior Custom Design - Option 2 (up to 3 colors) - \$6,000.00

Main Base in Pure White with Polyurethane Paint

Wing Tips painted in Polyurethane Color

N-Number in Vinyl

Painted Standard Scheme with Vinyl options

*\*Metallic or Pearl Paint and Vinyl have Additional cost*

*\*\*Only available on Colt SL*





# INTERIOR COLORS AND SCHEME

*Seats and Yokes with Dark and Light Beige, Carpet & Headliner Beige.*



# INTERIOR COLORS AND SCHEME

*Black Yokes and Black and Grey Seats with Carpet & headliner in Grey.*



# INTERIOR COLORS AND SCHEME

*Seats and Yokes with Terracotta and Black, Carpet & Headliner in Grey.*

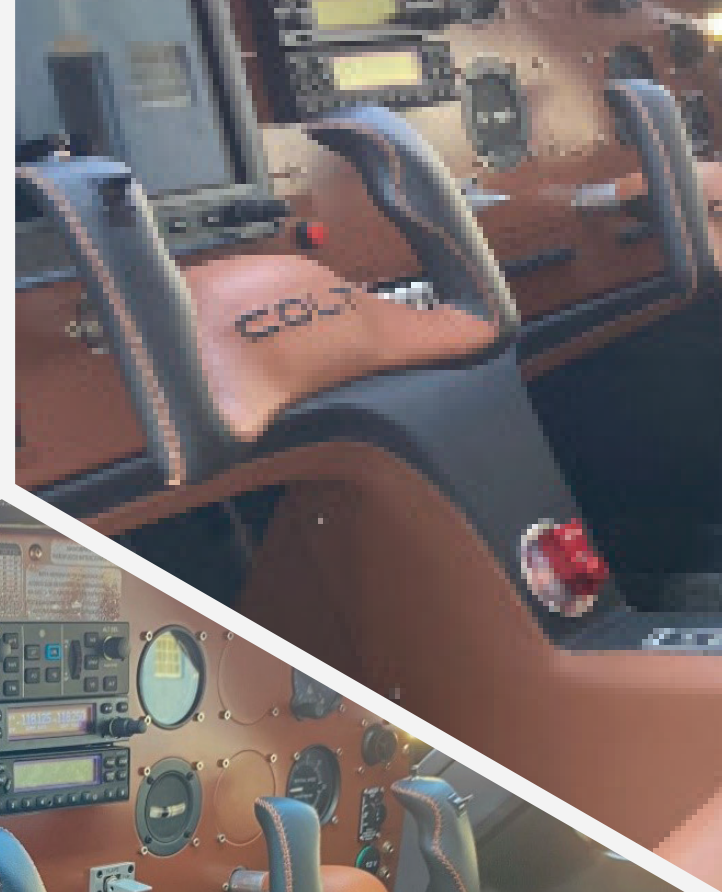

# ENGINE AND PROPELLER

## **Sterna S69CBMR**

3 Blades

69" Diameter

Fixed pitch and ground adjustable



## **Rotax 912 ULS - Standard**

Carburated Engine Dual Electronic Ignition

100 HP @ 5.800RPM 5.4 Gal/h @ 75%

power. 20 Amp internal energy Generator

TBO 2,000 hrs



# UPGRADE OPTIONS

## Parachute- \$15,000.00

\*\*\* Only available for the Colt in VFR configuration or 912ULS installed.

## Cabin Heating - \$1,500.00

## Rotax 912iS \$12,000.00

Electronic Fuel Injection System

Dual Electronic Ignition

100 HP @ 5.800RPM 20 to 30% Less Fuel Burn.

40 Amp internal energy Generator

TBO 2,000 hrs

*\* IS Engine under certification process in the Colt, consult a seller for more information.*

*\*All Prices are subjected to change without notice.*





**TEXAS AIRCRAFT MANUFACTURING  
CONTACT - ENGAGE@TEXASAIRCRAFT.COM  
KHDO SOUTH TEXAS REGIONAL AIRPORT  
508 VANDENBERG ROAD - HANGAR 5  
ZIP 78861 HONDO TEXAS**